

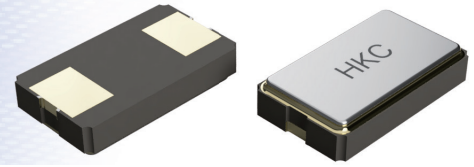

Ceramic SMD Crystals 6035SX Series

Model CC 2 PADS 6.0 X 3.5



Frequency Range : 7.00MHz to 125.00MHz

Features :

- High reliability & low cost unit
- Tight stability & extended temperature available
- Lead-free type
- AEC-Q200 Stress Qualified Component

QUARTZ
CRYSTALS

Standard Specifications

Item	Value
Frequency Range	7.00MHz to 125.00MHz
Frequency Tolerance	±20ppm, ±30ppm (or specify)
Frequency Tolerance over Temperature range	±30ppm ±100ppm
Operating Temperature Range	-40°C to +85°C -40°C to +125°C
Operable Temperature Range	-40°C to +130°C
Drive Level	50uW Typ (200uW Max)
Load Capacitance	8pF (or specify)

ESR Table

Frequency Range (MHz)	Standard ESR (Ohm)
7.00 ~ 7.99	180
8.00 ~ 8.99	150
9.00 ~ 9.99	100
10.00 ~ 10.99	80
11.00 ~ 11.99	50
12.00 ~ 13.99	40
14.00 ~ 50.00	30
40.00 ~ 125.00 (30/T)	150

Dimension

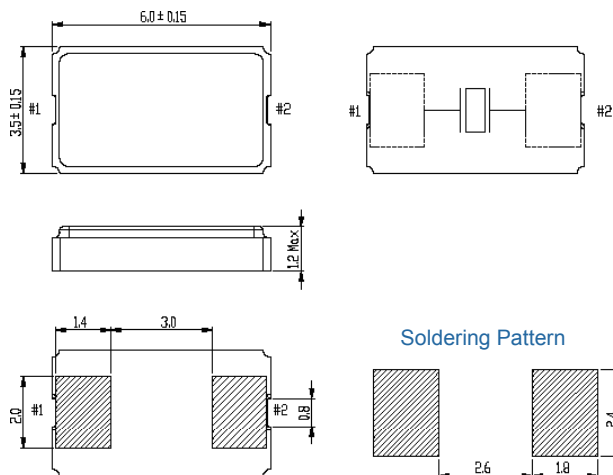

Note :

1. Manufacturer reserves the right to change the specification and content of this product for improvement without notification.
2. Custom specification is welcome. Please contact our sales representative for further details.
3. If the crystal is intended for applications which have direct impact on human life and properties, and require a high degree of reliability and safety concerns, customers must provide full information such as but not limit to the application, electrical and reliability specification at the inquiry beginning stage.
4. Customers have to agree to the "Guideline for handling crystal units" and "Standard Terms and Condition of Sales" which is printed in this catalog before placing orders to our company or our distributors. There are also unpredictable factors such as applied condition, oscillation margin and etc and customers must check them beforehand. In case of queries, please do not fail to send inquiry to our company before ordering.

Ver 1.1

