

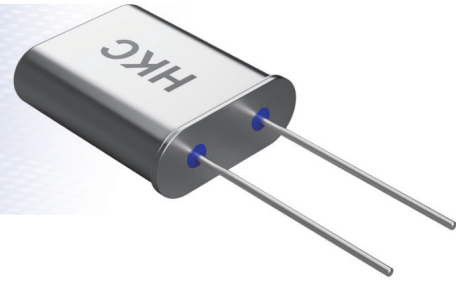

HC49U/49UT Crystals 49U Series

Model 9U / 9T / 9D HC49U/49UT Thru-hole



Frequency Range : 1.8432MHz to 120.70MHz

Features :

- High reliability & low cost unit
- Tight stability & extended temperature available
- Lead-free type

QUARTZ
CRYSTALS

Standard Specifications

Item	Value	
Frequency Range	1.8432MHz to 120.70MHz	
Frequency Tolerance	±20ppm, ±30ppm (or specify)	
Frequency Tolerance over Temperature range	±20ppm	±30ppm
Operating Temperature Range	-20°C to +70°C	-40°C to +85°C
Operable Temperature Range	-40°C to +90°C	
Drive Level	50uW Typ (300uW Max)	
Load Capacitance	12pF (or specify)	

ESR Table

Frequency Range (MHz)	Standard ESR (Ohm)
1.8432 ~ 2.39	550
2.40 ~ 2.99	300
3.00 ~ 3.49	150
3.50 ~ 3.99	100
4.00 ~ 5.49	80
5.50 ~ 5.99	60
6.00 ~ 7.99	50
8.00 ~ 10.99	40
11.00 ~ 12.99	35
13.00 ~ 15.99	30
16.00 ~ 50.00	25
26.00 ~ 120.70 (30/T)	100

Dimension

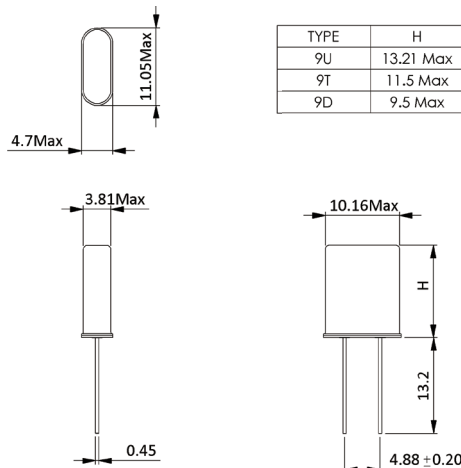

Note :

1. Manufacturer reserves the right to change the specification and content of this product for improvement without notification.
2. Custom specification is welcome. Please contact our sales representative for further details.
3. If the crystal is intended for applications which have direct impact on human life and properties, and require a high degree of reliability and safety concerns, customers must provide full information such as but not limit to the application, electrical and reliability specification at the inquiry beginning stage.
4. Customers have to agree to the "Guideline for handling crystal units" and "Standard Terms and Condition of Sales" which is printed this catalog before placing orders to our company or our distributors. There are also unpredictable factors such as applied condition, oscillation margin and etc and customers must check them beforehand. In case of queries, please do not fail to send inquiry to our company before ordering.

Ver 1.1

